

FIG. 2

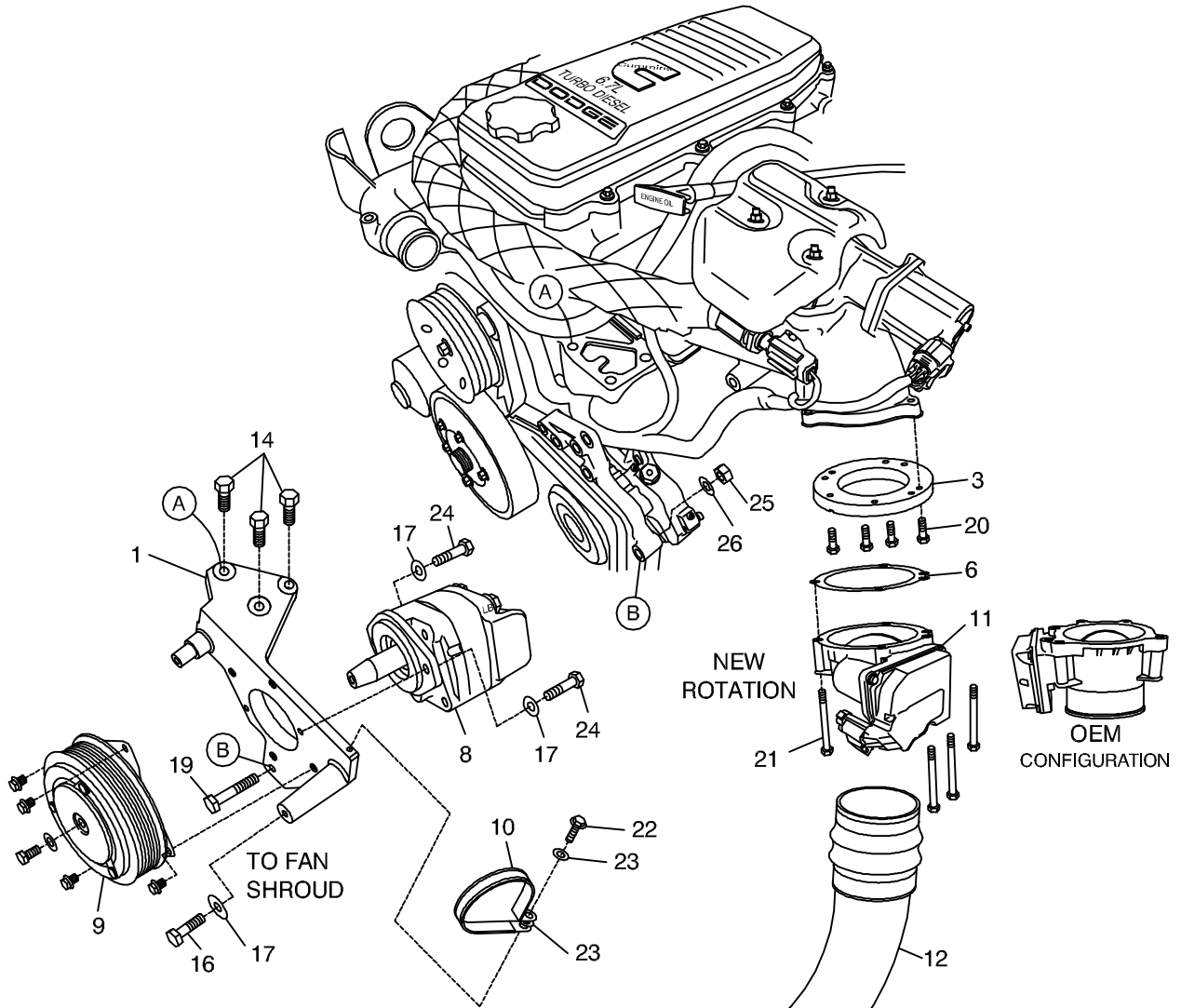
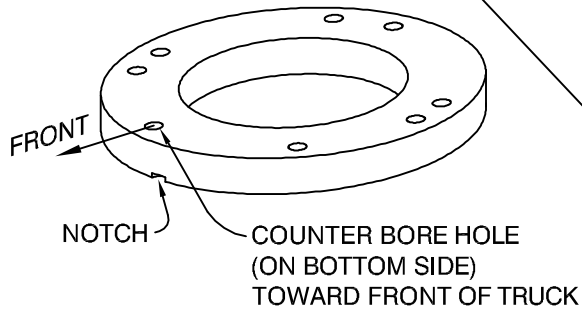
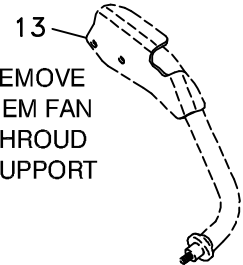

FIG. 3

ADAPTER RING ROTATION



13
REMOVE
OEM FAN
SHROUD
SUPPORT



DEWEZE Clutch Pump Kit 700494

Dodge 6.7L 2007+, no A/C, 15 HP Limit

INSTALLATION INSTRUCTIONS

1. The installation of this kit requires trained decision-making concerning clearances, tying components together, rerouting, or relocating OEM components, etc. It is impossible to describe all of the clearance and vibration points, etc. in the installation instructions. Therefore, the technician must exercise professional judgment to achieve the best quality installation.
2. Disconnect the battery.
3. Drain the coolant from the radiator to below the upper radiator hose. Remove that hose.
4. Remove the fan shroud support bracket (13). Remove the OEM belt.
5. Remove the intercooler tube (12) and the lower part of the air throttle body (11). Make sure the OEM gasket is still in place on the upper portion. Using four M6 x 16 bolts (20) mount the adapter ring (3) to the upper portion of the throttle body still attached to the truck with the counterbore holes facing down. The small notch at the outside diameter beside one of the counterbore holes indicates that hole points toward the front of the truck.
6. Place the new gasket (6) on top of the lower throttle body (rotated as shown in Fig. 2) and mount to the adapter ring. Use the OEM bolts (21). Replace the OEM intercooler tube.
7. Mount the pump (8) to the back of the pump plate (1) with two 3/8 x 1 1/4 bolts (24) and two 3/8 flat washers (17). Mount the hose adapters to the pump.
8. Mount the clutch coil (9a) to the pump bracket with four 1/4 x 1/2 flange bolts (9b). Mount the clutch pulley (9c) to the pump shaft with the 5/16 x 1 1/4 bolt (9d) and heavy flat washer (9e) making sure the key is in place on the shaft.
9. Run the hoses into the engine compartment. Pull them out far enough to attach them to the pump. Attach the top of the pump bracket (1) to the engine at Location A using three M10 x 40 bolts (14). Attach the bottom of the pump bracket to the power steering bracket at Location B with the 3/8 x 2 bolt (19), and the 3/8 lock washer (26) and 3/8 nut (25) on the back.
10. Install the belt (27) as shown in the diagram (Fig. 1).
11. Replace coolant and the radiator hose. Reconnect the battery.
12. Run the engine and check for any clearance or alignment problems. Adjust as needed.