

Dodge, 5.9L:D, 2003-06, A/C, A Pump, without Exhaust Brake and Transmission Control Module*

Bolt Packages:

Bracket	711907 (Inc. items 7-9, 11-13, 15, 16)
Idler pulley	None
Pulley	None
Tensioner	None

Bracket Assy.	None
Issue Date	12-21-07
Revision Date	E 12-18-08

Item Part No. Description

1.	711834	Pump plate	10.	-----	-----
2.	-----	-----	11.	110400	3/8-16 x 2 Bolt
3.	*	Pump	12.	710586	1/4-20 x 1.0 Self tap bolt
4.	742009	Clutch	13.	110673	1/4 Flat washer
5.	102036	Clamp	14.	110425	3/8-16 x 1 1/4 Bolt
6.	OEM	Fan shroud support, driver side	15.	110612	3/8 Nut
7.	110820	M10 x 1.5 x 35 Bolt	16.	110672	3/8 Lock washer
8.	110479	M10 x 1.5 x 30 Bolt	17.	742063	Belt, Micro-V K081298
9.	110676	3/8 Flat washer			

*The three mounting bolts at Location A must be clear of factory mounted options and modules.

FIG. 1
BELT DIAGRAM

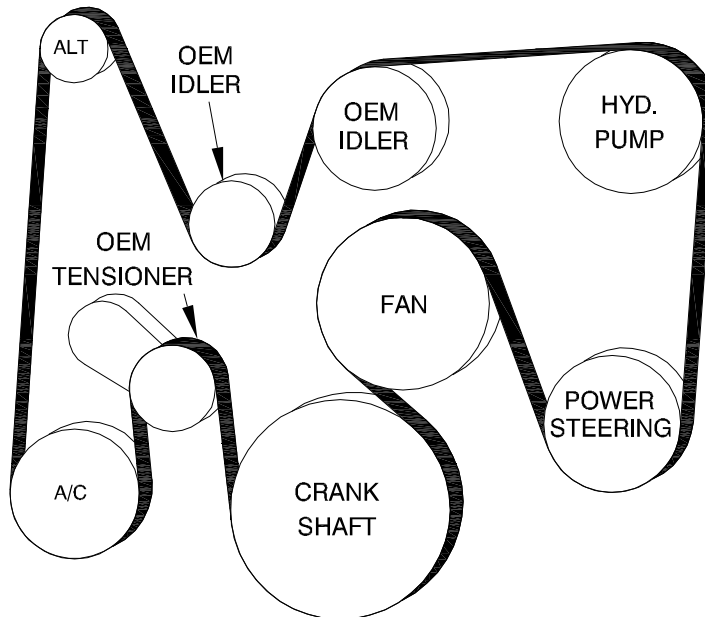

(A), (B), (C) ... Denotes bolt holes in engine to locate corresponding holes in Pump Brkt.

FIG. 2

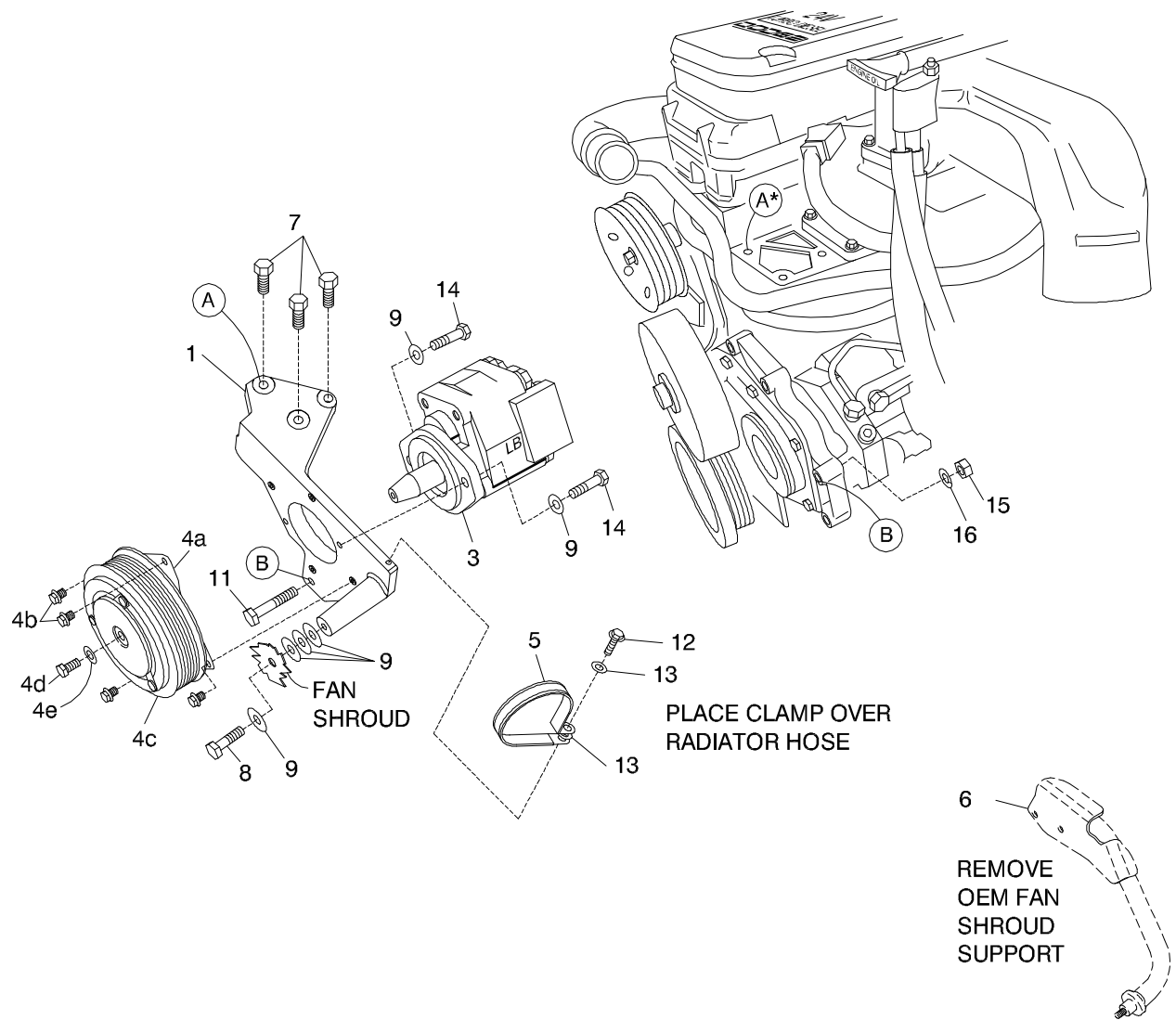

DEWEZE Clutch Pump Kit 700483

Dodge 5.9L 2003-2006

INSTALLATION INSTRUCTIONS

1. The installation of this kit requires trained decision-making concerning clearances, tying components together, rerouting, or relocating OEM components, etc. It is impossible to describe all of the clearance and vibration points, etc. in the installation instructions. Therefore, the technician must exercise professional judgment to achieve the best quality installation.
2. Disconnect the battery.
3. Drain the coolant from the radiator to below the upper radiator hose. Remove that hose.
4. Remove the OEM fan shroud support bracket (6). Remove the OEM belt.
5. Mount the pump (3) to the back of the pump plate (1) with two 3/8 x 1 1/4 bolts (14) and two 3/8 flat washers (9). Mount the hose adapters to the pump.
6. Mount the clutch coil (4a) to the pump bracket with four 1/4 x 1/2 flange bolts (4b). Mount the clutch pulley (4c) to the pump shaft with the 5/16 x 1 1/4 bolt (4d) and heavy flat washer (4e) making sure the key is in place on the shaft.
7. Run the hoses into the engine compartment. Pull them out far enough to attach them to the pump. Attach the top of the pump bracket (1) to the engine at Location A using three M10 x 40 bolts (7). Attach the bottom of the pump bracket to the power steering bracket at Location B with the 3/8 x 2 bolt (11), and the 3/8 lock washer (16) and 3/8 nut (15) on the back.
8. Attach the fan shroud to the long boss on the pump plate with the M10 x 30 bolt (8) and 3/8 flat washer (9). If needed, place three 3/8 flat washers between the shroud and the bracket.
9. Install the belt (17) as shown in the diagram (Fig. 1).
10. Place the clamp (5) over the radiator hose and replace the hose. Attach the clamp to the bracket with the 1/4 x 1 bolt (12) and two 1/4 flat washers (13). Replace the coolant. Reconnect the battery.
11. Run the engine and check for any clearance or alignment problems. Adjust as needed.