

Bracket Assy.	None	
Bolt Packages:		
Bracket	711419	(Inc. items 6, 10-13, 19, 21-24, 26)
Pulley	711420	(Inc. items 20, 28)
Fan spacer	711421	(Inc. items 18, 19)
Tensioner	711422	(Inc. items 11, 17)

Make	Isuzu	
Engine	4.751L	
Fuel	Diesel	
Year	2002-	
Equipment	Turbo, A/C	
Revised	NC	1-30-02

Item	Part No.	Description	Item	Part No.	Description
1.	711416	Engine mount bracket	16.	743002	Tensioner
2.	711418	Pump plate	17.	110676	3/8 Flat washer
3.	740358	Crank pulley	18.	110559	M8 x 40 x 1.25 Bolt
4.	700254	Fan spacer	19.	110674	5/16 Lock washer
5.	711414	Shroud extender bracket	20.	110314	M16 x 80 x 1.5 Bolt
6.	711415	Shroud extender spacer	21.	110671	7/16 Lock washer
7.	*	Pump	22.	110689	M10 Lock washer
8.	740162	Clutch	23.	110665	5/16 Flat washer
9.	OEM	Fan mount plate	24.	110558	M8 x 50 x 1.25 Bolt
10.	110569	M8 x 65 x 1.25 Bolt	25.	OEM	Bolt
11.	110217	M10 x 70 x 1.5 Bolt	26.	110643	M8 x 1.25 Nut
12.	110535	7/16-14 x 1 1/2 Bolt	27.	OEM	Nut
13.	110426	5/16-18 x 1/2 Flange bolt	28.	110669	5/8 Flat washer
14.	OEM	Alternator pivot bolt	29.	110271	3/8 Lock washer, .55 O.D. x .13 thick
15.	110465	3/8-16 x 1 1/4 Socket head bolt	30.	742002	Belt/Micro-V K060425

* See master list for pump part number.

FIG. 1

MOVE FAN SHROUD FORWARD

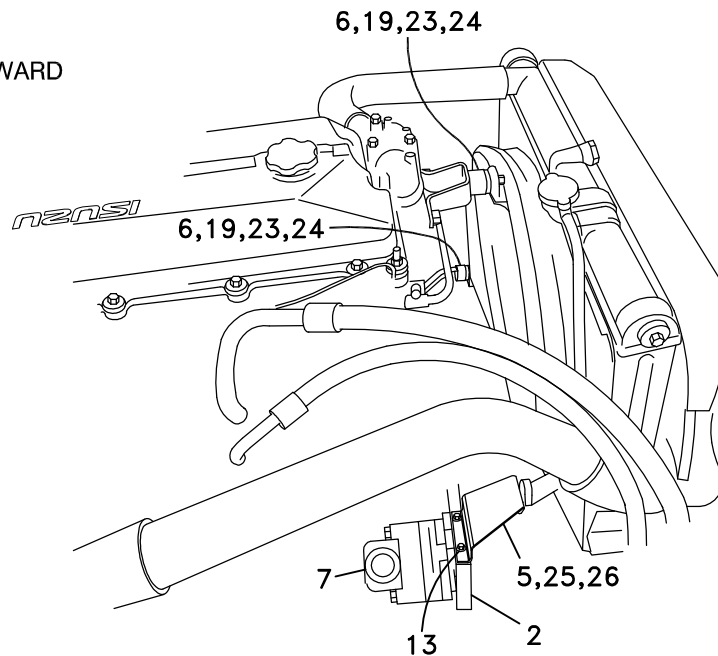
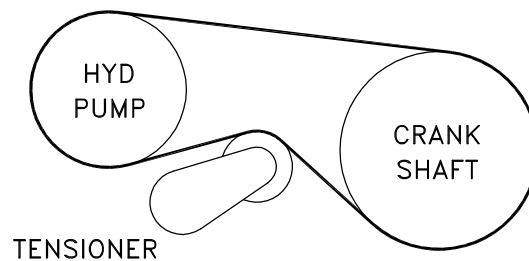

FIG. 2

BELT DIAGRAM



Clutch Pump Kit 700395

FIG. 3

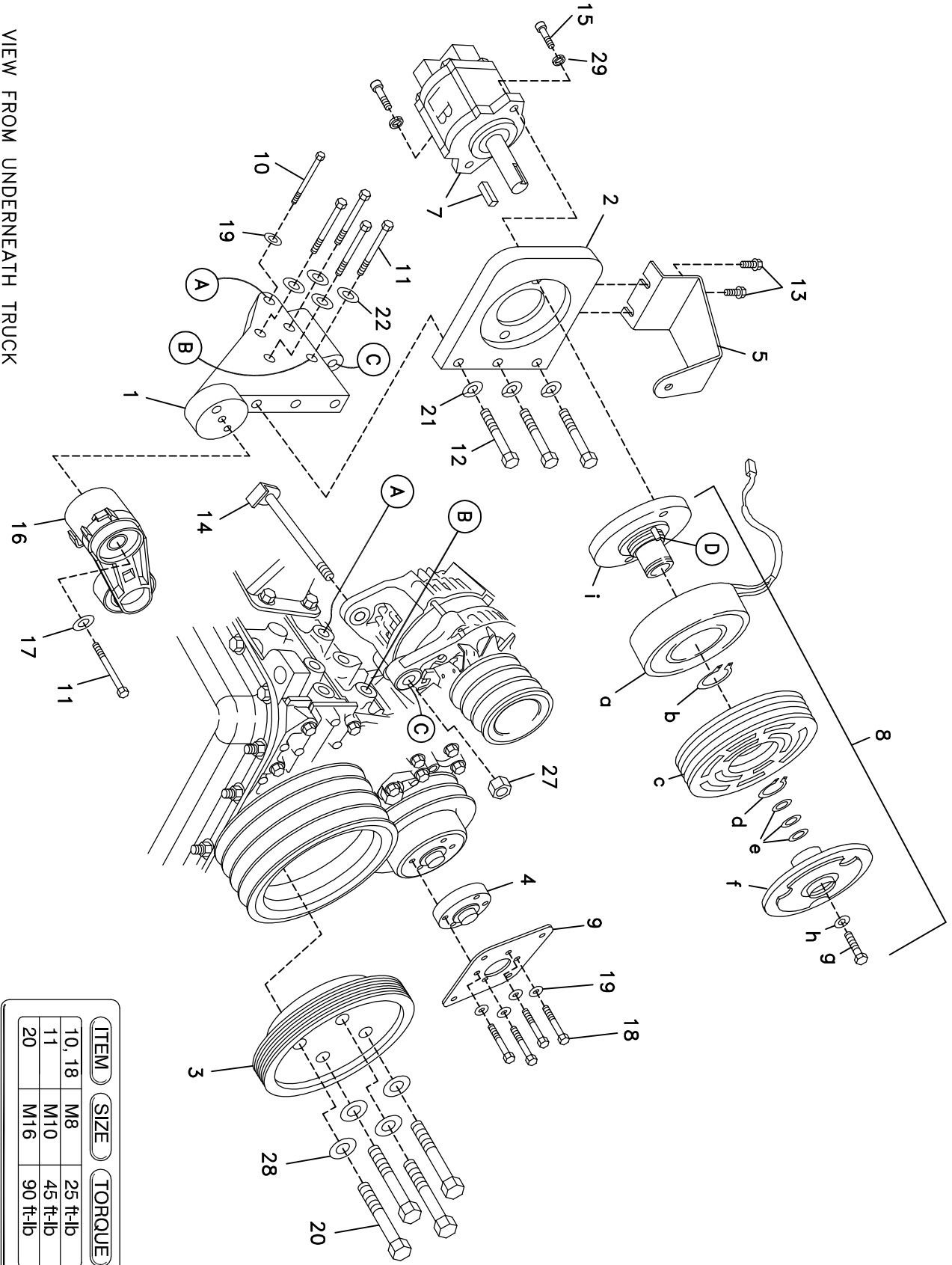

ITEM	SIZE	TORQUE
10, 18	M8	25 ft-lb
11	M10	45 ft-lb
20	M16	90 ft-lb

VIEW FROM UNDERNEATH TRUCK

DewEze

Clutch Pump Kit

Clutch Pump Kit
700395
ISUZU
4.75L
'AA' mount
2002-

INSTALLATION INSTRUCTIONS

1. The front of the truck will need to be jacked up and set on blocks, as the installation will be underneath the truck.
2. Disconnect the battery.
3. Remove the bolts supporting the fan shroud at three locations. Save one bolt to be used on reinstallation.
4. Unbolt the fan from the square mounting plate. Lay the fan forward into the shroud. Save the nuts to use again.
5. Remove the square plate (9) from the water pump. Place the fan spacer (4) on the water pump. Place the OEM square plate on the fan spacer. Fasten the plate and fan spacer with four M8 x 40 bolts (18) and four 5/16 lock washers (19). Torque to 25 ft-lb.
6. Remove the inspection cover on the bottom of the bell housing to hold the engine from turning when the pulley bolts are removed and tightened back up. Remove the OEM crank pulley bolts. Install the crank pulley (3) with four M16 x 80 bolts (20) and four M16 flat washers (28). Torque to 90 ft-lb. Replace the inspection cover.
7. Loosen the alternator belt. Remove the pivot bolt and nut from the bottom of the alternator. Save these, as they will be used over again. Slide the bolt out of the alternator. Remove the fan shroud bracket and the alternator mount from the engine. These will not be used over.
8. Slide the engine bracket (1) between the alternator mounting lugs at location C and attach with the OEM alternator bolt (14) and OEM nut (27). Bolt the bracket to the engine using the M8 x 65 bolt (10) at location A with a 5/16 lock washer (19). Torque this bolt to 25 ft-lb. Insert four M10 x 70 bolts (11) and four M10 lock washers (22) in the remaining holes. Torque these to 45 ft-lb.
9. Tighten the alternator belts. Tighten any bolts that have been loosened.
10. Hold pump (7) onto back of mounting plate (2) and clutch hub (8i) onto front of mounting plate, making sure clutch wire and anti-rotation pin (G) on front of hub is on the top. Place two 3/8 x 1 1/4 socket head bolts (15) with 3/8 high collar lock washers (29) through pump, through mounting plate and thread into hub.
11. Slide coil (8a) over hub, aligning hole in the back plate of coil with the anti-rotation pin (G) in the hub. The wires from the coil should be on the same side as the pin (G). Install large snap ring (8b) to hold coil in place.
NOTE: THE BEVEL ON BOTH SNAP RINGS MUST FACE AWAY FROM THE PUMP. REFER TO INSTRUCTION SHEET FOR THE CLUTCH FOR CORRECT INSTALLATION OF SNAP RINGS.
12. Slide clutch pulley (8c) onto hub. Install small snap ring (8d) to hold pulley in place.
13. Place the key (7) onto the pump shaft. Slide the hub/armature (8f) onto the pump shaft aligning the keyways.
NOTE: SET THE AIR GAP BETWEEN THE HUB/ARMATURE AND THE PULLEY USING SHIMS (8e) ACCORDING TO INSTRUCTION SHEET FOR CLUTCH.
14. Thread bolt (8g) and lock washer (8h) into pump shaft. Torque to value in clutch instruction sheet.

15. Install the tensioner (16) onto the engine bracket with the M10 x 70 bolt (11) and 3/8 flat washer (17). Torque to 45 ft-lb.

16. Place the belt (30) on the clutch first then stroke the tensioner downward and slip the belt over the crank pulley.

17. Attach the fan back onto the square mounting plate (9) using the OEM nuts.

18. Mount the fan shroud extension bracket (5) onto the pump plate with two 5/16 x 1/2 flange bolts (13). Attach the bracket to the fan shroud using the OEM bolt (25) and the M8 nut (26). Do not tighten any of these bolts until all fan shroud bolts are in place. Attach the fan shroud at the top and driver's side using the round spacer (6) with an M8 x 50 bolt (24), a 5/16 lock washer (19), and a 5/16 flat washer (23) at each place. Tighten all the bolts.

19. Run the engine and check for any clearance or alignment problems. Adjust as needed.