

711212	Bracket Assy. (Inc. item 1)		Kit No.	700346
711214	Bracket Bolt Pkg. (Inc. items 2, 5, 6, 10)		Make	Dodge
None	Pulley Bolt Pkg.		Engine	8.0L V-10
None	Idler Bolt Pkg.		Fuel	Gas
None	Fan Spacer Bolt Pkg.		Year	1999
			Equipment	w/o AC
			Revised	A 1-18-00

ITEM	PART #	DESCRIPTION
1.	711212	Pump plate
2.	711213	Spacer
3.	*	Pump
4.	740183	Clutch/8-groove, 4.75" serp.
5.	110540	3/8-16 x 4.50 Bolt
6.	110548	3/8-16 x 5.75 Bolt
7.	110465	3/8-16 x 1.25 Socket head bolt
8.	110672	3/8 Lock washer
9.	OEM	Nut
10.	110542	3/8-16 x 5.50 Bolt
11.	OEM	Tensioner
12.	OEM	Bolt
13.	740279	Belt/Micro-V K071134

- 4a. Coil
- 4b. Snap ring/large
- 4c. Pulley Bolt
- 4d. Snap ring/small
- 4e. Shim
- 4f. Hub/armature
- 4g. Bolt
- 4h. Lock washer
- 4i. Hub/clutch

These items referenced in instructions. They are not available separately.

* See master list for pump part number.

FIG. 1

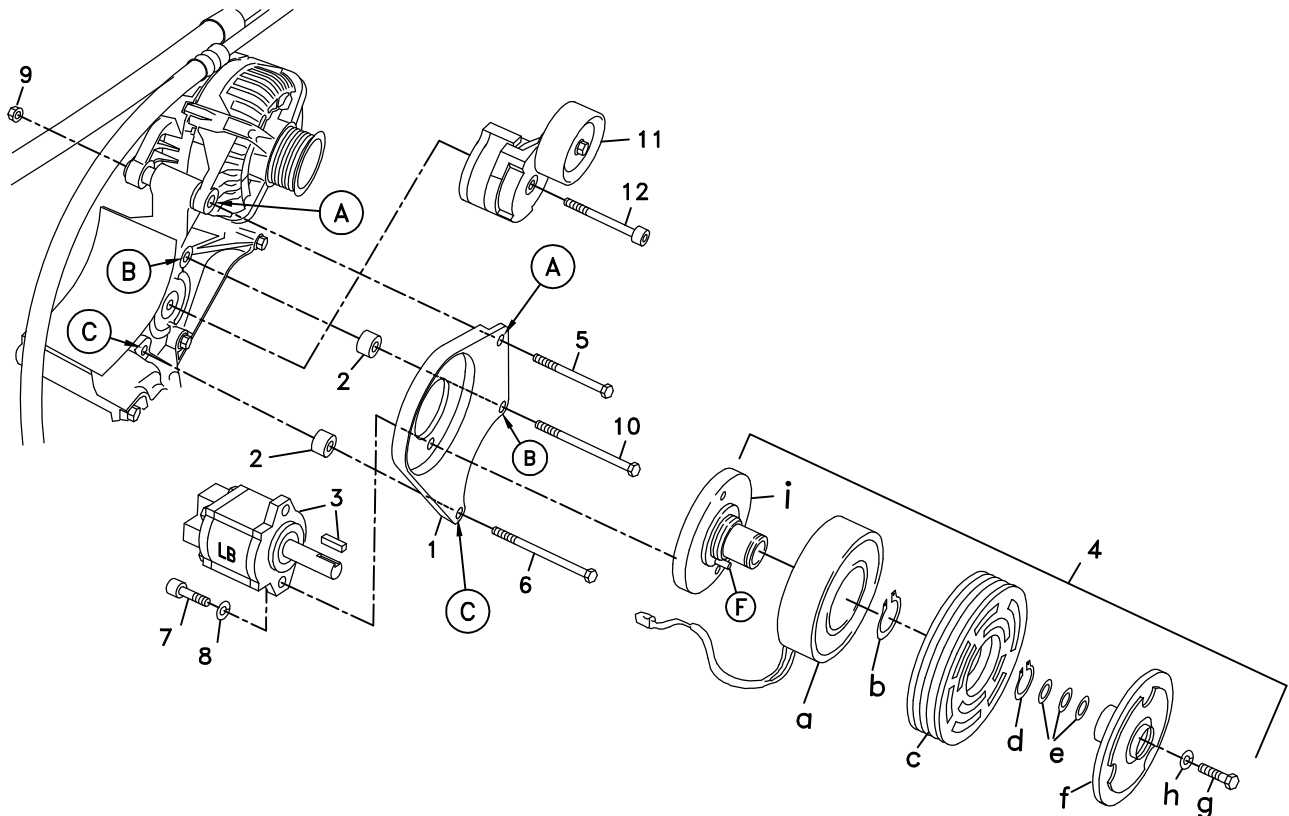

(A),(B),(C)... Denotes bolt holes in engine to locate corresponding holes in Pump Brkt.

FIG. 2

BELT DIAGRAM

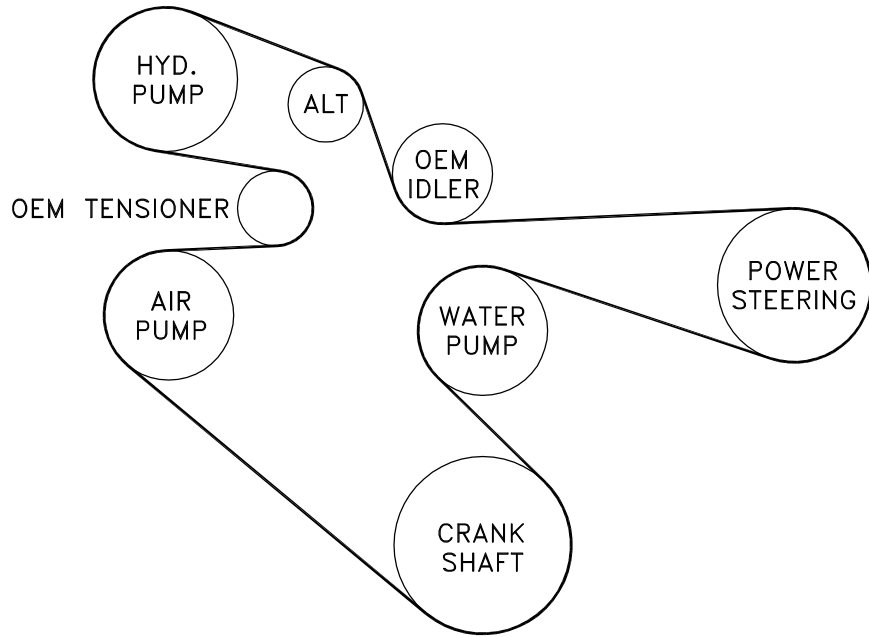
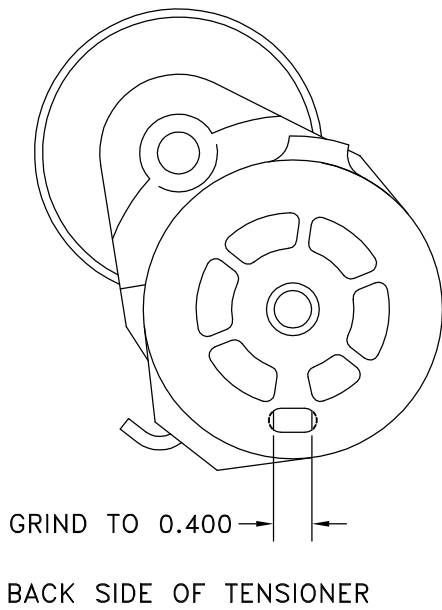

FIG. 3



DewEze

Clutch Pump Kit
#700346
Dodge 8.0L V-10
Without A/C
1999

INSTALLATION INSTRUCTIONS

NOTE: Suction hose to pump must be a wire braid hose; minimum 1" I.D. for 7 & 9 gpm pumps. Installations with smaller suction hoses will void the pump warranty.

1. Disconnect battery.
2. Remove OEM serpentine belt.
3. The OEM belt tensioner needs to be rotated to properly tension the new belt configuration. Remove the tensioner. On the mounting surface on the back of the tensioner is a locating lug. Grind the ends of this lug so its length is .400" as shown in Fig. 3. Replace the tensioner so the locating lug fits in the notch in the casting directly below the hole for the mounting bolt at location D. This will place the idler pulley in approximately the 2 o'clock position.
4. Remove OEM bolt and nut from alternator pivot at location A. Save the nut to use again. Remove the OEM bolts at locations B and C. None of the bolts will be used again.
5. Hold pump (9) onto back of mounting plate (2) and clutch hub (10i) onto front of mounting plate, making sure anti-rotation pin (G) on front of hub is on the side that will be away from the engine. Place two 3/8 x 1 1/4 bolts (14), 3/8 lock washers (15), and 3/8 flat washers (23) through pump, through mounting plate and thread into hub.
6. Slide coil (10a) over hub, aligning hole in the back plate of coil with the anti-rotation pin (G) in the hub. The wires from the coil should be on the same side as the pin (G). Install large snap ring (10b) to hold coil in place.

NOTE: THE BEVEL ON BOTH SNAP RINGS MUST FACE AWAY FROM THE PUMP. REFER TO INSTRUCTION SHEET FOR THE CLUTCH FOR CORRECT INSTALLATION OF SNAP RINGS.

7. Slide clutch pulley (10c) onto hub. Install small snap ring (10d) to hold pulley in place.
8. Place the key (14) onto the pump shaft. Slide the hub/armature (10f) onto the pump shaft aligning the keyways.
NOTE: SET THE AIR GAP BETWEEN THE HUB/ARMATURE AND THE PULLEY USING SHIMS (10e) ACCORDING TO INSTRUCTION SHEET FOR CLUTCH.
9. Thread bolt (10g) and lock washer (10h) into pump shaft. Torque to value in clutch instruction sheet.
10. Mount the pump plate with pump to the engine using the 3/8 x 5.50 bolt (10) with a spacer (2) behind the bracket at location B, and the 3/8 x 5.75 bolt (6) with a spacer (2) at location C. Insert the 3/8 x 4.50 bolt (5) through the bracket at location A and through the alternator. Tighten the OEM nut on the back of the bolt.
11. Install the new serpentine belt (11) as shown in Fig. 2. The belt and the OEM pulleys are 7-groove. The clutch pulley is 8-groove. Place the belt in the front 7 grooves of the clutch pulley to line the belt up properly, leaving the rear groove open.

12. Connect the battery.
13. Run the engine and check for any clearance or alignment problems. Adjust as needed.