

-----	Bracket Assy. (See item 1)		Kit No.	700331
711125	Bracket Bolt Pkg. (Inc. item 2)		Make	Ford
None	Pulley Bolt Pkg.		Engine	7.3L
None	Idler Bolt Pkg.		Fuel	Diesel
None	Fan Spacer Bolt Pkg.		Year	1999
			Equipment	w/o A/C
			Revised	A 3-30-99

ITEM	PART #	DESCRIPTION
1.	711113	Pump mount plate
2.	110486	8mm x 30mm Bolt
3.	-----	-----
4.	110465	3/8NC x 1 1/4 Skt. hd. bolt
5.	110672	3/8 Lock washer
6.	110676	3/8 Flat washer
7.	*	Pump
8.	710918	Key
9.	740183	Clutch, serpentine
9a.	-----	Coil
	9b.	----- Snap ring/large
	9c.	----- Pulley
	9d.	----- Snap ring/small
	9e.	----- Shim
	9f.	----- Hub/armature
	9g.	----- Bolt
	9h.	----- Lock washer
	9i.	----- Hub/clutch
	10.	OEM Micro-V Belt

Items 9a - 9i are not available individually. They are listed only for reference in instructions.  
 \* The only pumps available for this kit are 'AA' mount. See master list for pump part number.

FIG. 1

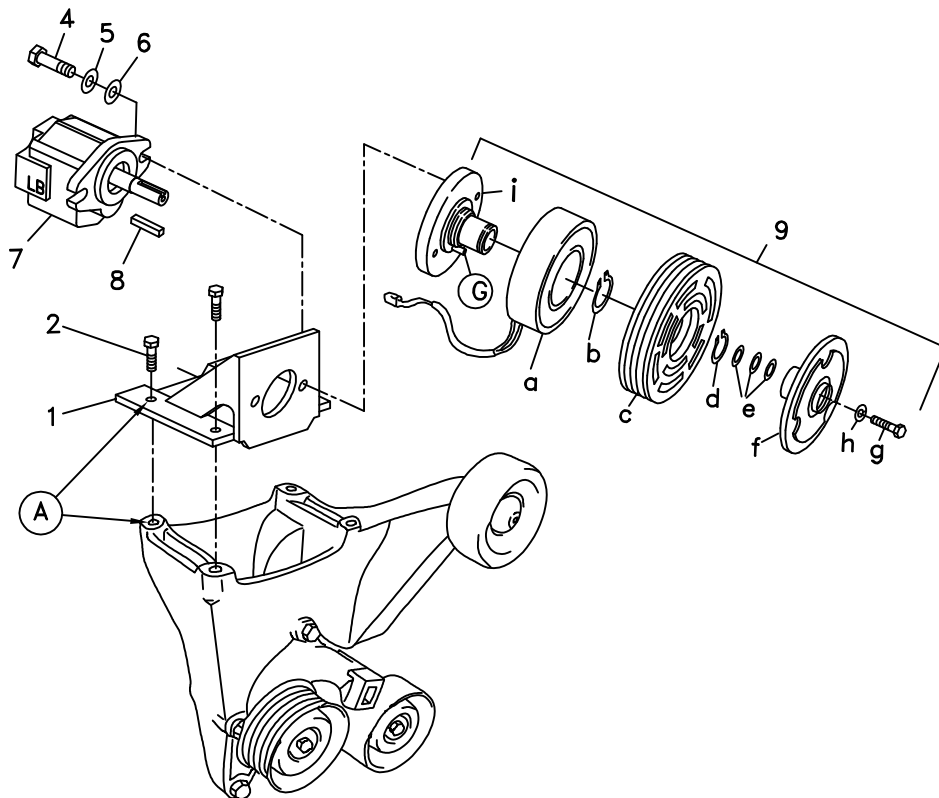

(A),(B),(C)... Denotes bolt holes in engine to locate corresponding holes in Pump Brkt.

FIG. 2

BELT DIAGRAM

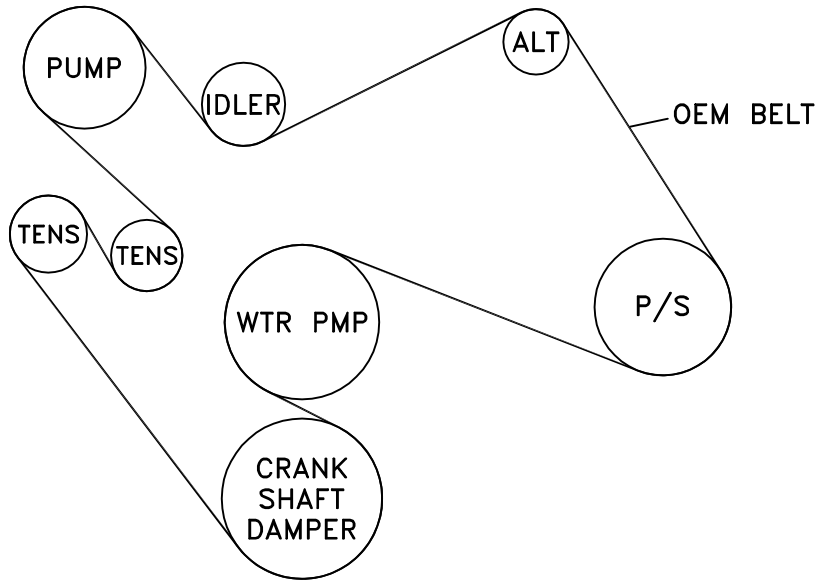

# DewEze

Clutch Pump Kit  
#700331  
Ford 7.3L  
Without A/C  
1999

## INSTALLATION INSTRUCTIONS

**NOTE: Suction hose to pump must be a wire braid hose; minimum 1" I.D. for 7 & 9 gpm pumps; Installations with smaller suction hoses will void the pump warranty.**

1. Disconnect battery.
2. Remove OEM serpentine belt.
3. Remove OEM idler mounting bracket from top of air conditioning/power steering bracket.
4. Hold pump (7) onto back of mounting plate (1) and clutch hub (9i) onto front of mounting plate, making sure anti-rotation pin (G) on front of hub is on the side that will be away from the engine. Place two 3/8 x 1 1/4 socket head bolts (4), 3/8 lock washers (5), and 3/8 flat washers (6) through pump, through mounting plate and thread into hub.
5. Slide coil (9a) over hub, aligning hole in the back plate of coil with the anti-rotation pin (G) in the hub. The wires from the coil should be on the same side as the pin (G). Install large snap ring (9b) to hold coil in place.  
**NOTE: THE BEVEL ON BOTH SNAP RINGS MUST FACE AWAY FROM THE PUMP. REFER TO INSTRUCTION SHEET FOR THE CLUTCH FOR CORRECT INSTALLATION OF SNAP RINGS.**
6. Slide clutch pulley (9c) onto hub. Install small snap ring (9d) to hold pulley in place.
7. Place the key (8) onto the pump shaft. Slide the hub/armature (9f) onto the pump shaft aligning the keyways.  
**NOTE: SET THE AIR GAP BETWEEN THE HUB/ARMATURE AND THE PULLEY USING SHIMS (9e) ACCORDING TO INSTRUCTION SHEET FOR CLUTCH.**
8. Thread bolt (9g) and lock washer (9h) into pump shaft. Torque to value in clutch instruction sheet.
9. Bolt on pump mounting plate (1) using four 8mm x 30mm (2) in holes A at top of OEM air conditioner bracket.
10. Install OEM belt as shown in fig. 2.
11. Reconnect the battery.