

# DewEze

## CLUTCH PUMP KIT

710080	Bracket Assy. (Inc. items 1-3, 29, 30)	Kit No.	700321
711111	Bracket Bolt Pkg. (Inc. items 7, 9, 10, 28)	Make	Chevy
None	Pulley Bolt Pkg. (Inc. items )	Engine	(5.7L) 350
711013	Idler Bolt Pkg. (Inc. items 4,16,17)	Fuel	Gas
711014	Idler Bolt Pkg. (Inc. items 4,15,17)	Year	1996-97
None	Fan Spacer Bolt Pkg. (Inc. item )	Options	With A/C
		Revised	E 7-28-00

ITEM	PART #	DESCRIPTION
1.	711056	Base plate
2.	711110	Pump plate
3.	711059	Hose holder
4.	711009	Idler bushing
5.	740151	Idler pulley
6.	*	Pump
7.	110435	3/8NC x 1 1/2 bolt
8.	740162	Clutch, serpentine
9.	110178	3/8NC x 1 1/2 Skt hd bolt
10.	110437	3/8NC x 3/4 Wiz flange bolt
11.	OEM	Bolt
12.	OEM	Bolt
13.	OEM	Bolt
14.	OEM	Nut
15.	110180	10mm x 60mm x 1.50 Bolt
16.	110179	7/16 x 2 3/4 Bolt
17.	110670	7/16 Flat washer
18.	110395	3/8NC x 1 Skt hd bolt
19.	-----	-----
20.	110676	3/8 Flat washer
21.	OEM	Bolt
22.	OEM	Hose holder
23.	700214	Air conditioner bracket
24.	OEM	Engine lift hook
25.	OEM	Nut
26.	OEM	Power steering pulley
27.	740265	Belt, Micro-V K061120
28.	110426	5/16NC x 1/2 Wiz bolt
29.	711008	Tab/rear
30.	711058	Tab/front
31.	120101	Hose splice
32.	511084	Hose clamp
33.	740242	Idler pulley

\* See Master List For Pump Part No.

FIG. 1

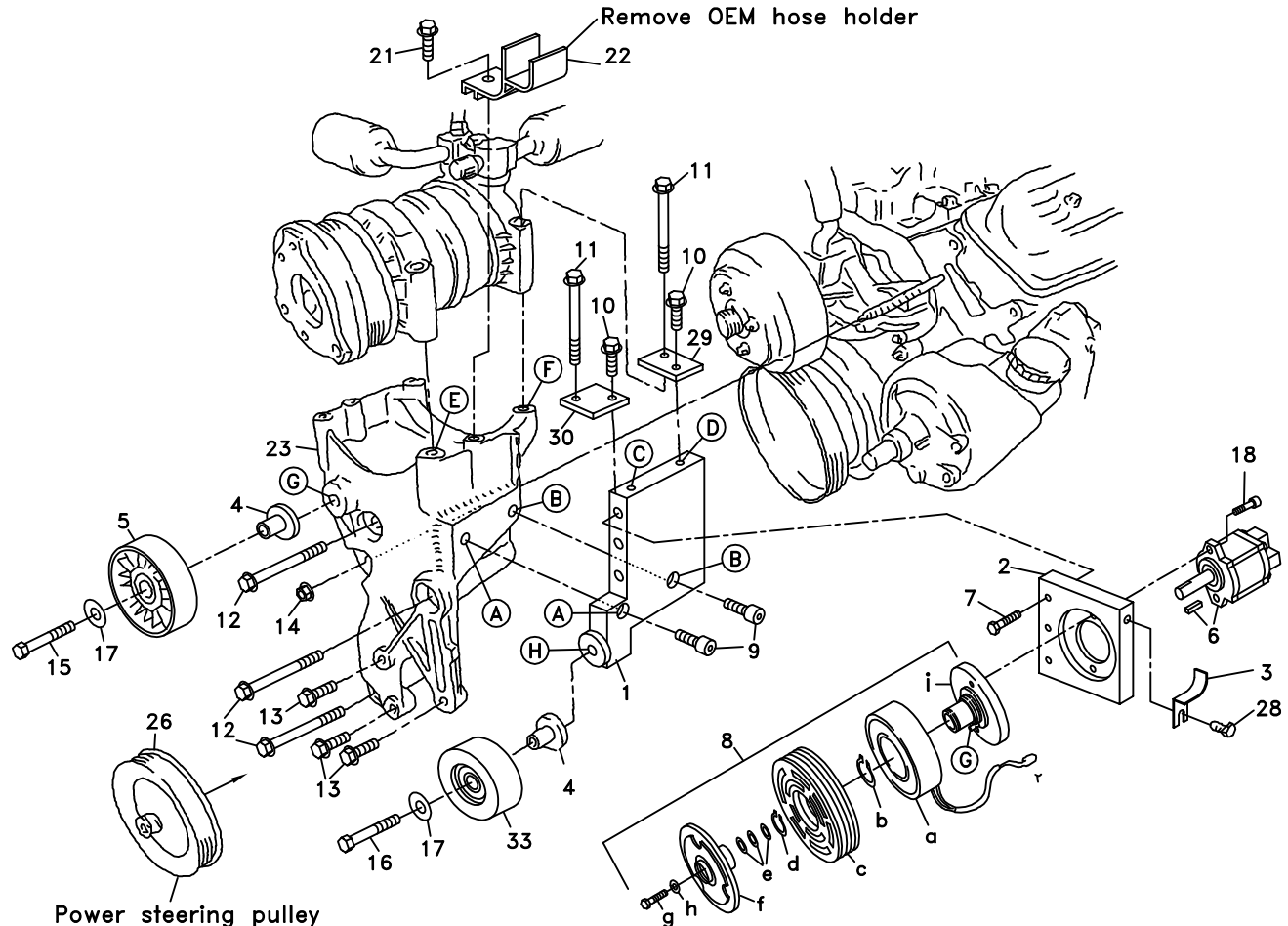

(A) Denotes bolt holes in engine to locate corresponding holes in Pump Brkt.

FIG. 2

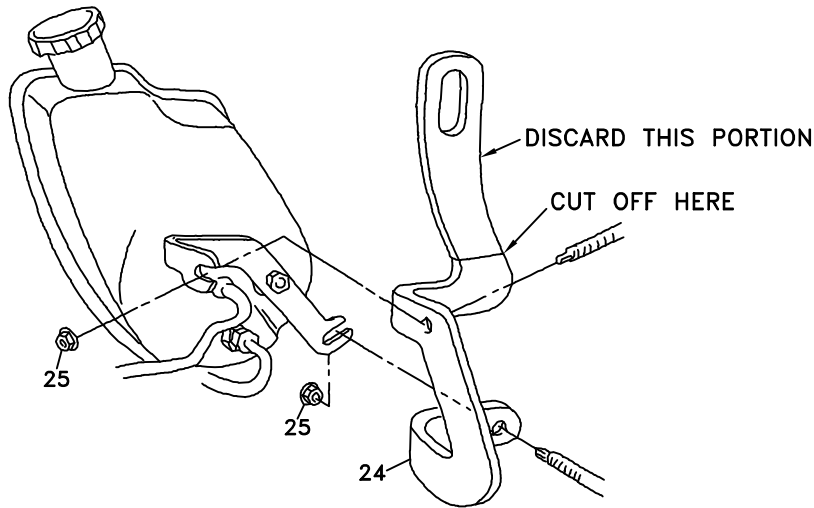

FIG. 3  
FOR VAN  
INSTALLATION  
ONLY

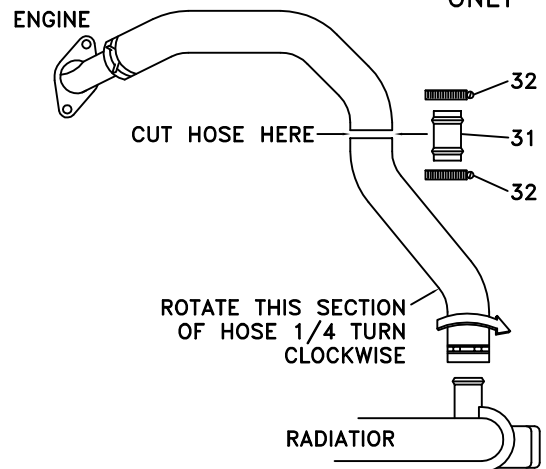
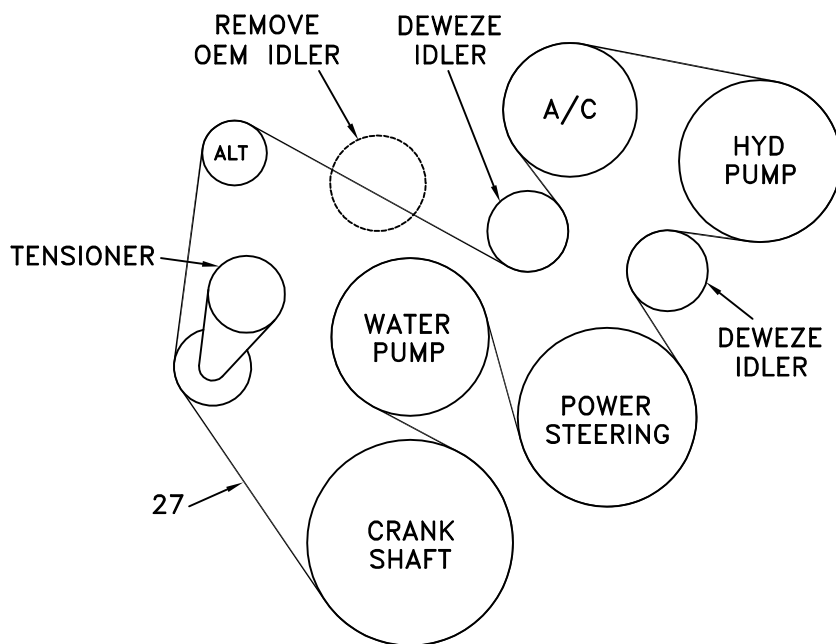

FIG. 4



# DewEze

Clutch Pump Kit  
#700321  
Chevy 350  
Pickup & Van  
With A/C  
1996-97

## INSTALLATION INSTRUCTIONS

**NOTE: Suction hose to pump must be a wire braid hose; minimum 1" I.D. for 7 & 9 gpm pumps; 1 1/4" I.D. for 12 & 17 gpm pumps. Installations with smaller suction hoses will void the pump warranty.**

1. Disconnect battery.
2. Remove fan and fan shroud.
3. Remove bolts from air conditioner (11) and radiator hose support (21). Remove hose support (22).
4. Remove power steering pulley (26).
5. Remove bolts (12, 13) and nut (14) mounting air conditioner bracket to engine.
6. Remove power steering pump from engine (2 nuts on backside).
7. Remove engine lifting bracket (24) behind power steering pump.
8. Cut lifting bracket as shown in Fig. 2. Discard upper slotted portion.
9. Replace lifting bracket back on engine.
10. Replace power steering pump and secure with OEM nuts.
11. **FOR INSTALLATION IN VAN ONLY:** Cut upper radiator hose at location shown in Fig. 3. Loosen hose clamp at radiator and turn that section of hose 1/4 turn clockwise. Tighten hose clamp. Place DewEze hose clamps (32) on both ends of hose at cut. Slide both ends of hose onto hose splice (31) and tighten clamps. This will move hose away from rotating clutch pulley.
12. Bolt DewEze air conditioner bracket (23) in place using OEM bolts (12, 13) and nut (14).
13. Replace power steering pulley.
14. Bolt air conditioner compressor in place on bracket with only two bolts (11) on passenger side.
15. Bolt on pump base plate (1) using two 3/8 x 1 1/2 socket head bolts (9) in holes A and B.
16. Place wide tab (30) on top of base plate (1) and air conditioner compressor toward the front at holes C and E, using the OEM bolt (11) in air conditioner compressor and 3/8 x 1 wiz bolts (10) in base plate. Place narrow tab (29) on top of base plate and air conditioner compressor toward the rear at holes D and F using the OEM bolt (11) in compressor and 3/8 x 1 wiz bolt (10) in base plate.

17. Bolt pump plate (2) on base plate (1) using three 3/8 x 1½ bolts (7).
18. Hold pump (6) onto back of mounting plate (2) and clutch hub (8i) onto front of mounting plate, making sure anti-rotation pin (G) on front of hub is on the side that will be away from the engine. Place two 3/8 x 1 socket head bolts (18) through pump, through mounting plate and thread into hub.
19. Slide coil (8a) over hub, aligning hole in the back plate of coil with the anti-rotation pin (G) in the hub. The wires from the coil should be on the same side as the pin (G). Install large snap ring (8b) to hold coil in place.  
**NOTE: THE BEVEL ON BOTH SNAP RINGS MUST FACE AWAY FROM THE PUMP. REFER TO INSTRUCTION SHEET FOR THE CLUTCH FOR CORRECT INSTALLATION OF SNAP RINGS.**
20. Slide clutch pulley (8c) onto hub. Install small snap ring (8d) to hold pulley in place.
21. Place the key (6) onto the pump shaft. Slide the hub/armature (8f) onto the pump shaft aligning the keyways.  
**NOTE: SET THE AIR GAP BETWEEN THE HUB/ARMATURE AND THE PULLEY USING SHIMS (8e) ACCORDING TO INSTRUCTION SHEET FOR CLUTCH.**
22. Thread bolt (8g) and lock washer (8h) into pump shaft. Torque to value in clutch instruction sheet.
23. Place hose holder (3) on top right edge of pump plate with 5/16 x 1/2 wiz flange bolt (28).
24. Mount clutch coil (8) using four wiz bolts provided with clutch. Mount clutch pulley using bolt and heavy flat washer provided with clutch.
25. Bolt idler pulley (5) using 7/16 x 2 3/4 bolt (16), 7/16 flat washer (17), and bushing (4) into pump plate at hole (H).
26. Bolt idler pulley (5) using 10mm x 60mm bolt (15), 7/16 flat washer (17), and bushing (4) into air conditioner bracket at hole (G).
27. Install belt (27) as shown in Fig. 4.
28. Reconnect the battery.
29. Run the engine and check for any clearance or alignment problems. Adjust as needed.
30. Place fan and shroud into position.
31. Run the engine again, checking for any problems.